

GENUINE REAR SPOILER

IMPORTANT POINTS IN PAINTING

PART NAME: REAR SPOILER
PART NUMBER: 0000-8Y-H50/GHK1 V4 920/G44B V4 920
VEHICLE: MAZDA6

1 PAINT AREAS

SURFACE TREATMENT

- a : Paint same as body color
- b : No masking required

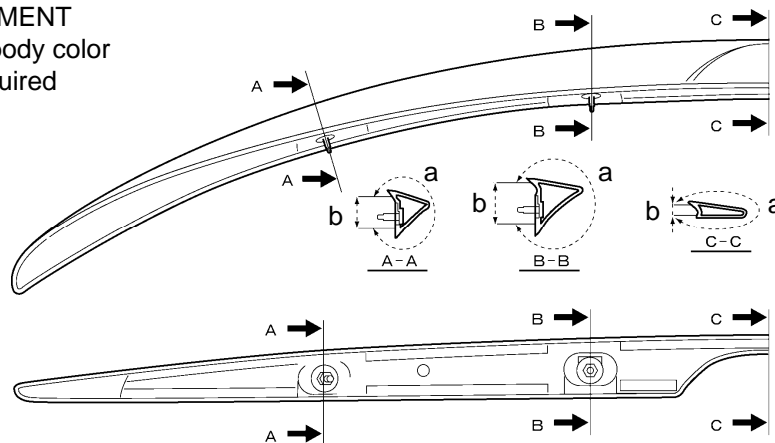

2 PAINT SPECIFICATION

⚠ CAUTION

- Paint characteristics vary according to paint type. Check manufacturer specifications before painting.

- Use two-component urethane paint. (Main component: acrylic polyol, Curing agent: isocyanate)

⚠ CAUTION

- Do not use lacquer paints because their weatherproofing and adhesion characteristics are poor.

- Dilute with the prescribed thinner before painting.
- When painting, use a spray gun to apply the paint evenly.

3 DRYING GUIDELINES

60° C: Approx. 2 hours

80° C: Approx. 1 hour

Baking Time

- Do not dry at temperatures above 80° C.
- Refer to the instructions of the paint being used for details on paint viscosity, thickness, and drying instructions.

4 HANDLING OF BAKED PAINT

After baking, do not touch the painted product until it has cooled down completely.

GENUINE REAR SPOILER

COMPONENT PARTS INSTALLATION MANUAL

In order to maintain the optimum condition, read this manual carefully and familiarize yourself with this product after completing painting.



- The  **CAUTION** symbols in this manual indicate safety precautions at the time of installation. Read the instruction carefully to prevent injuries or possible damage to your vehicle.

 **CAUTION:** Indicates a situation in which bodily injury or damage to the vehicle could result if the caution is ignored.

- Do not modify the rear spoiler.
- Do not install the rear spoiler in any way other than described in the following instructions.
- If you have any questions about the use of the accessory, ask your Mazda dealer for proper advice before using it.
- Mazda and its suppliers are not responsible for injuries, accidents, and damage to persons and property that arise from the failure of the dealer or installer to follow these instructions.

PART NAME: REAR SPOILER
PART NUMBER: 0000-8Y-H50
GHK1 V4 920
G44B V4 920
VEHICLE: MAZDA6

1

FINISHED IMAGES

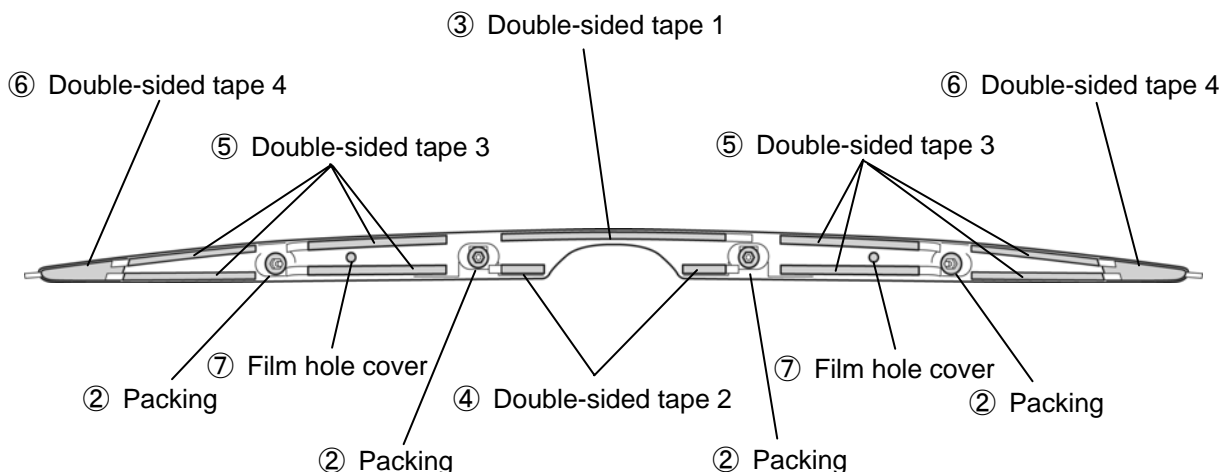







2

REQUIRED PARTS (Check the following parts prior to installation)

⚠ CAUTION

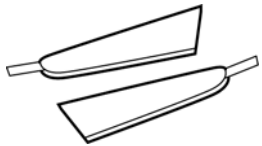
- Check the chart shown below and make sure that no parts are missing.
- Make sure all the component parts are free from dirt, scratches, or damages.

<p>① Rear spoiler</p>  <p>Quantity 1</p>	<p>② Packing</p>  <p>Quantity 4</p>	<p>③ Double-sided tape 1 (Length: 232 mm {9.1 in})</p>  <p>Quantity 1</p>
<p>④ Double-sided tape 2 (Length: 45 mm {1.8 in})</p>  <p>Quantity 2</p>	<p>⑤ Double-sided tape 3 (Length: 140 mm {5.5 in})</p>  <p>Quantity 8</p>	<p>⑥ Double-sided tape 4</p>  <p>Quantity 2</p>
<p>⑦ Film hole cover</p>  <p>Quantity 2</p>		

3

INSTALLING PROCEDURE (Assembly after painting)

Rear spoiler assembly

1. Remove any oil or dirt on the back of the rear spoiler (attachment surface) with IPA (isopropyl alcohol).

⚠ CAUTION

- When installing the packing and protectors to the rear spoiler, always apply **primer** to the installation position on the rear spoiler beforehand.

2. Peel off the paper backings of the double-sided tape in the order of ⑥→③④⑤, then attach them to the rear spoiler.
3. Peel off the paper backings of the packing ② and film hole cover ⑦, then attach them to the rear spoiler.

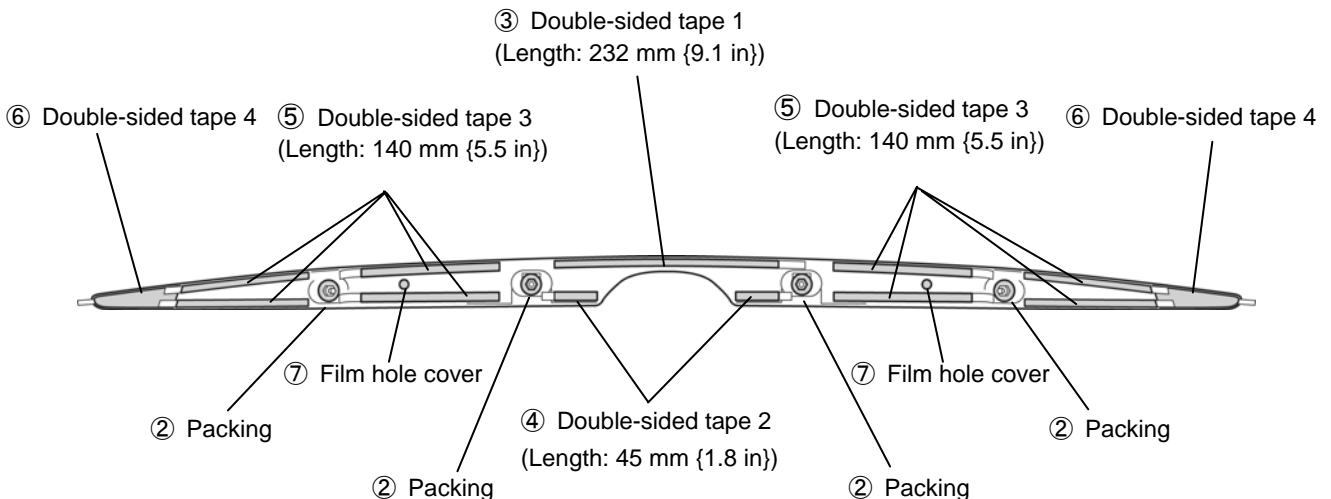





③④⑤⑥⑦: within scribe lines.

GENUINE REAR SPOILER

INSTALLATION AND USER'S INSTRUCTIONS

Thank you for purchasing a genuine Mazda accessory.
Before removal and installation, be sure to thoroughly read these instructions.
Please read the contents of this booklet in order to properly install and use the rear spoiler. Your safety depends on it.
Keep these instructions with your vehicle records for future reference.

WARNING

- There are several  **WARNING** and  **CAUTION** sections in this booklet concerning safety when installing or removing the rear spoiler. Always read and follow them in order to prevent injuries, accidents, and possible damage to the vehicle.
 -  **WARNING:** Indicates a situation in which serious injury or death could result if the warning is ignored.
 -  **CAUTION:** Indicates a situation in which bodily injury or damage to the vehicle could result if the caution is ignored.
- For areas indicating the tightening torque in this instruction manual, tighten to the specified torque using a torque wrench. For areas in which the tightening torque is indicated inside parentheses (), the tightening torque is indicated as a reference value, however tightening using a torque wrench is not necessary
- Do not modify the rear spoiler.
- Do not install the rear spoiler in any way other than described in the following instructions.
- If in any doubt, please ask your Mazda dealer to install the accessory in order to prevent errors in installation.
- If you have any questions about the use of the accessory, ask your Mazda dealer for proper advice before using it.
- Mazda and its suppliers are not responsible for injuries, accidents, and damage to persons and property that arise from the failure of the dealer or installer to follow these instructions.
- To ensure safety and reliability of the work, installation, removal and disposal work must be carried out by an Authorized Mazda Dealership.
- Be careful not to lose removed parts, and be sure that they are kept free from scratches, grease or other dirt.

PART NAME: REAR SPOILER
PART NUMBER: 0000-8Y-H50
GHK1 V4 920
G44B V4 920
VEHICLE: MAZDA6

NOTE

To the dealer

- Please turn over these instructions to the customer after installation.

To the customer

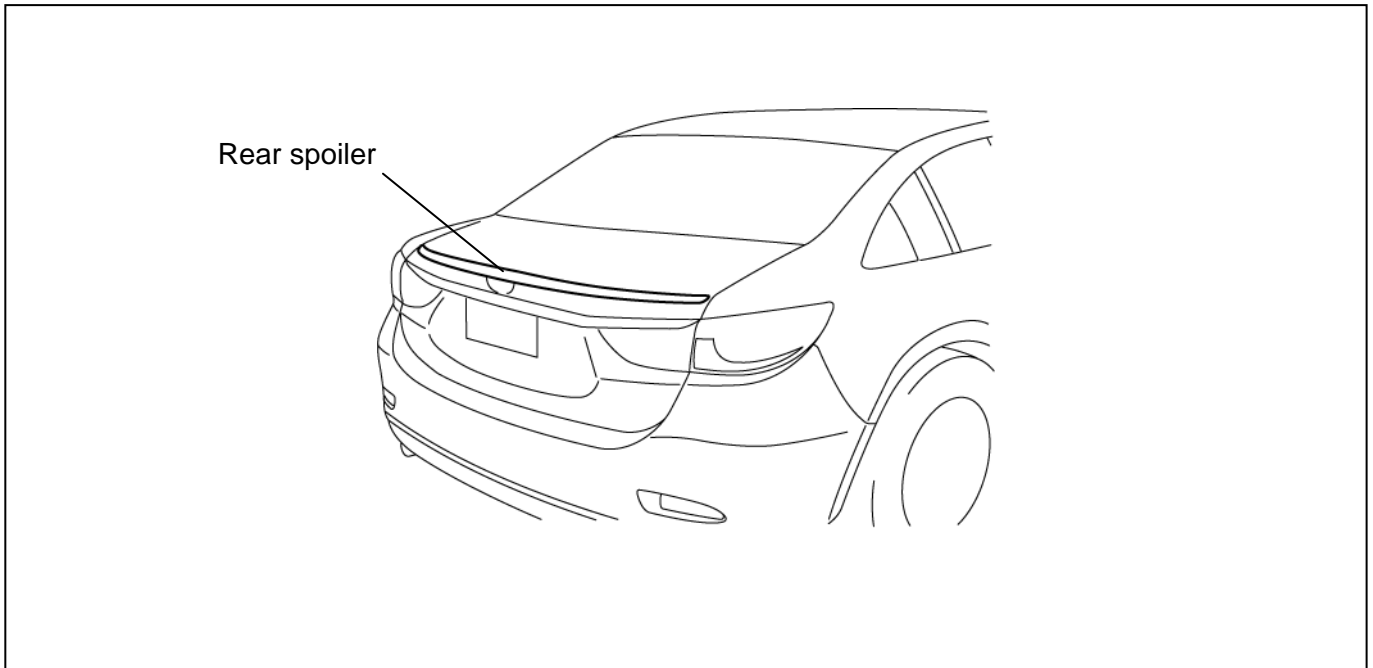

- Keep these instructions after installation. The instructions may be necessary for installing other optional parts or removal of this accessory.
- Should the vehicle or this accessory be resold, always leave these instructions with it for the next owner.

1. INSTALLATION VIEW



2. PARTS

- Before installation, verify that the kit includes all the following parts and that they are free of dirt, scratches, or damage.

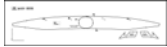
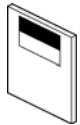
Part	Part name	Qty	Part	Part name	Qty	Part	Part name	Qty
	Rear spoiler	1		Nut	4		Template	1
	Installation Instructions	1						

3. BEFORE INSTALLATION

■ REQUIRED TOOLS

☆ Flathead screwdriver ☆ Socket wrench (10 mm) ☆ Fastener remover ☆ Torque wrench ☆ measure
 ☆ Electric drill (3 mm, 6 mm, 10 mm drill bits) ☆ Round file ☆ Punch ☆ Utility knife ☆ Scissors ☆ Tape
 ☆ Soft, clean cloth ☆ IPA (isopropyl alcohol) ☆ white gasoline ☆ Touch-up paint (Genuine product)

⚠ WARNING

Park the vehicle on a flat, level surface, set the selector lever to P (AT vehicles) or the shift lever to 1st or R (MT vehicles), apply the parking brake and block the wheels so that the vehicle does not move during installation.

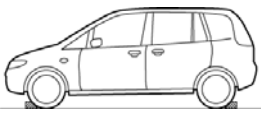

⚠ CAUTION

<p>Be sure to cover the vehicle body with protectors or mats to prevent stains, scratches and damage when removing/installing the vehicle parts</p>	<p>Using improper tools may cause damage and or broken parts. Use the correct tool for the job.</p>	<p>Wrap protective tape around screwdrivers and fastener remover tools to prevent scratching the vehicle.</p>	<p>Put the removed parts and the parts in the kit on the protective sheet to prevent scratches.</p>

Advice

Refer to the Workshop Manual for removal and installation of vehicle parts.
 Not following the procedures for removal/installation in the Workshop Manual could result in an accident or vehicle malfunction.



4. VEHICLE PART REMOVAL

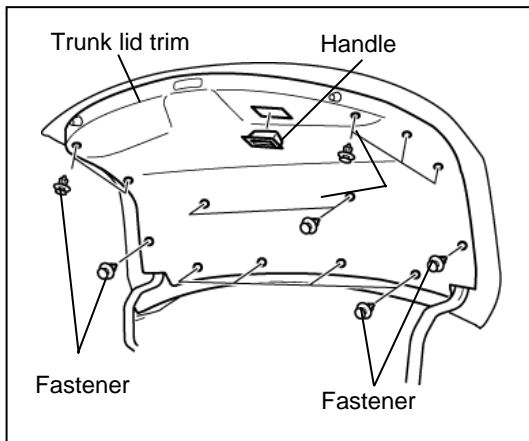

Trunk lid trim removal

1. Remove the fasteners (13).
2. Pull the handle outward and remove the trunk lid trim.

5. REAR SPOILER INSTALLATION

Rear spoiler installation preparation

- Cover the rear spoiler with a clean cloth to prevent scratches or other damage.

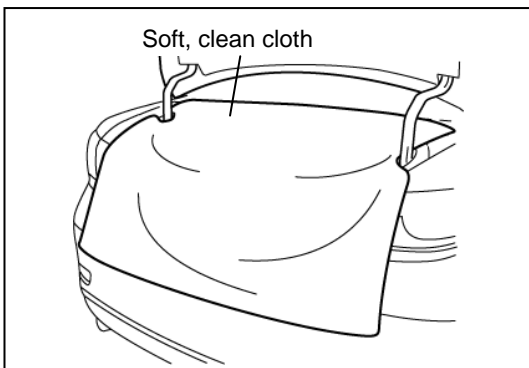

Vehicle protection

1. When drilling the trunk lid, cover the vehicle with a soft, clean cloth to prevent shavings from penetrating the trunk.

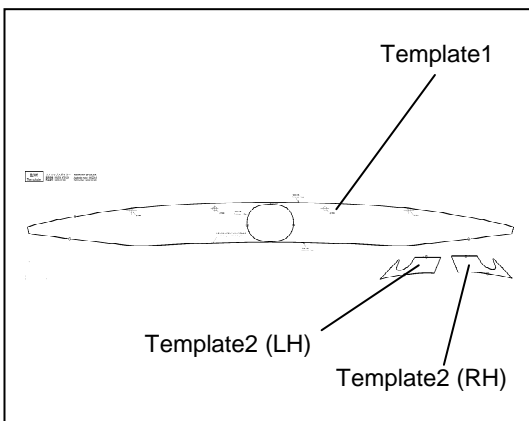

Body hole drilling

1. Cut out the templates1, 2 with scissors along the cut lines.

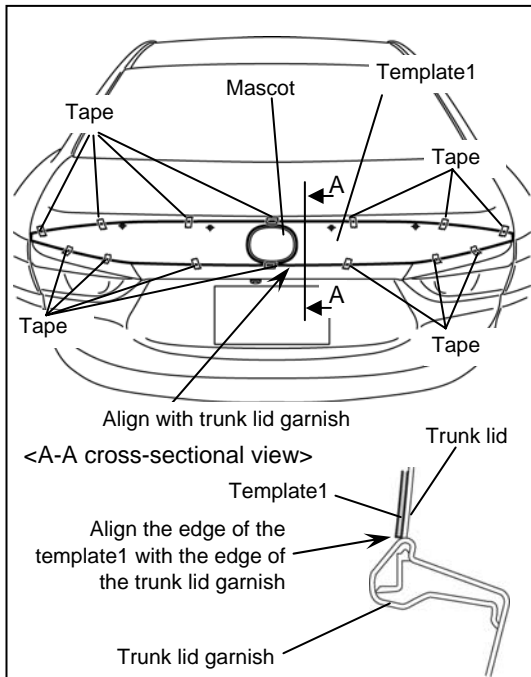

2. Align template 1 with the mascot and trunk lid garnish, and secure the template with tape.

- Make sure the template is not twisted or detached when affixing it to the body.
- Make sure the template is in the center of the trunk lid when affixing it to the body.

3. Tap drill hole marks with a punch in the crosshair marks on the rear spoiler installation templates (4 locations).

- Before marking with a punch, verify again that the marked hole positions of the template is in the center of the trunk lid.
- Do not punch the trunk lid, otherwise it may be deformed.

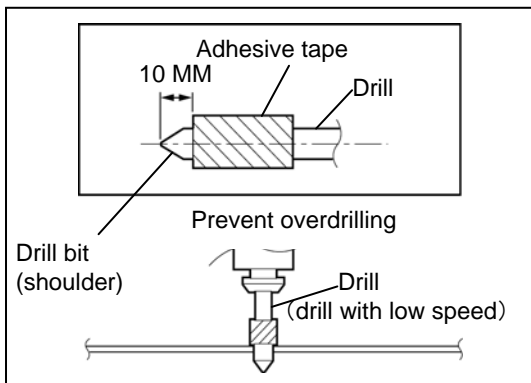

4. Peel off the template1.

5. Wrap the drill bit with duct tape as shown in the figure.

6. Set the drill speed to low.

- Always use a drill with a rotation speed adjustment, otherwise the trunk lid may deform.
- Be careful when handling drills and other sharp objects.
- To prevent scratching and overdrilling, wrap the drill bit with duct tape.

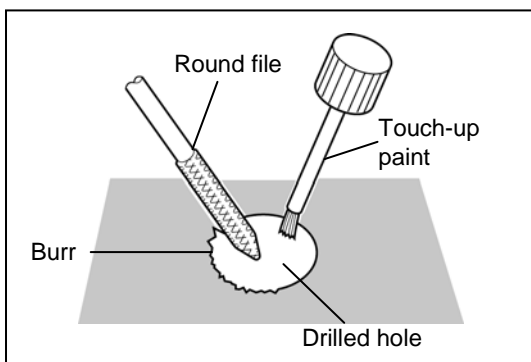

7. With the drill bit pointed perpendicular to the trunk lid, drill a hole in the marked position in stages.

Drill hole diameter: From 3 mm to 6 mm and then 10 mm diameter (1 location)

8. Remove any metal burrs around the drilled hole with a round file.

- Make sure to remove burrs from the surface so that the surface of the trunk lid is smooth.

9. Remove all shavings using an air compressor.

- Completely remove drill filings from the trunk and cabin, otherwise they may cause abnormal noise.

10. Degrease the trunk lid using IPA (isopropyl alcohol).

11. Apply touch-up paint.

12. Remove the soft cloth for the vehicle.

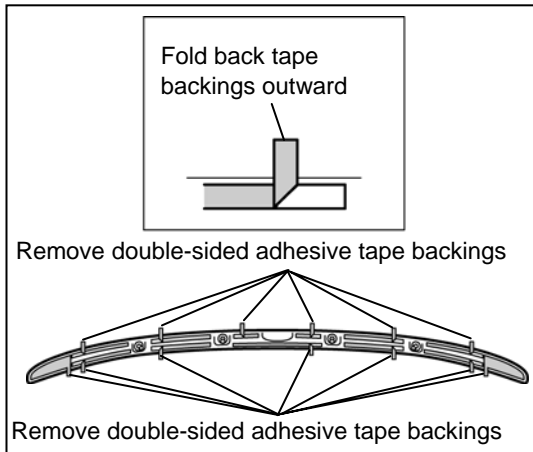

Rear spoiler installation

1. Fold the double-sided adhesive tape (13 locations) outward so that they can be removed easily.

- Do not remove too much of the tape backing.

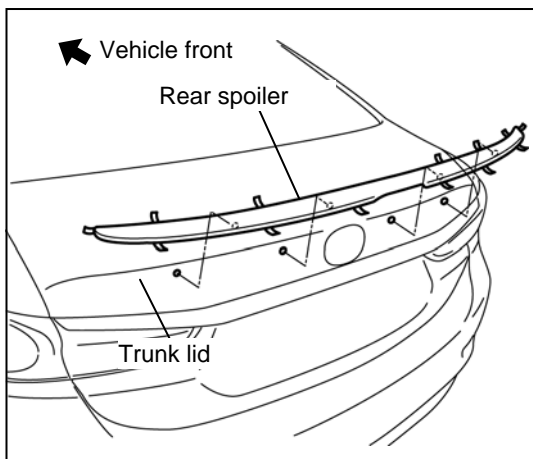

2. Hold both ends of the rear spoiler and align the rear spoiler screw positions with the installation hole (10 mm diameter) of the trunk lid and insert lightly.

- Do not insert the rear spoiler screw positions 100% down into the installation hole. Otherwise, the double-sided adhesive tape on the backside of the rear spoiler will adhere to the trunk lid, and the installation position cannot be adjusted.

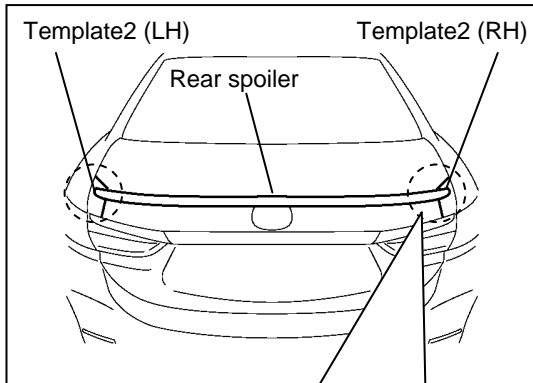

3. Align template2 with both ends of the trunk lid and rear spoiler, and adjust the height.

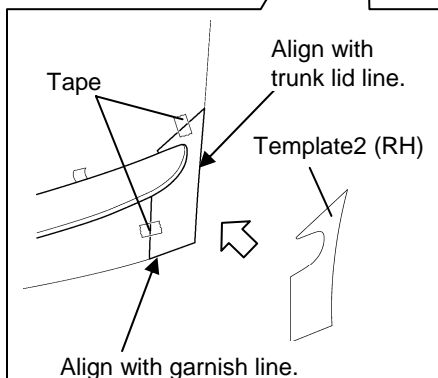

*The figure shows the right side, however, perform the same procedure for the left side.

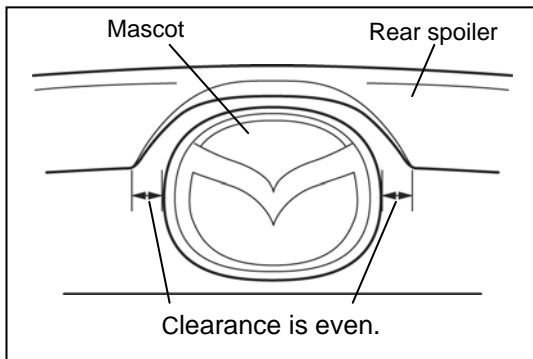

4. Align the following clearances and height to determine the installation position.
 - Make sure the clearance on the upper part and both sides of the rear spoiler and the mascot is even.

- Make sure that the outward-folding double-sided adhesive tape (13 locations) does not get stuck on the trunk lid.

5. Peel off the template2.

6. Press in from the surface of the rear spoiler and install the rear spoiler to the trunk lid.

- Press the rear spoiler in gently. If it is pressed in with excessive force, the trunk lid will deform making it difficult to install the rear spoiler.

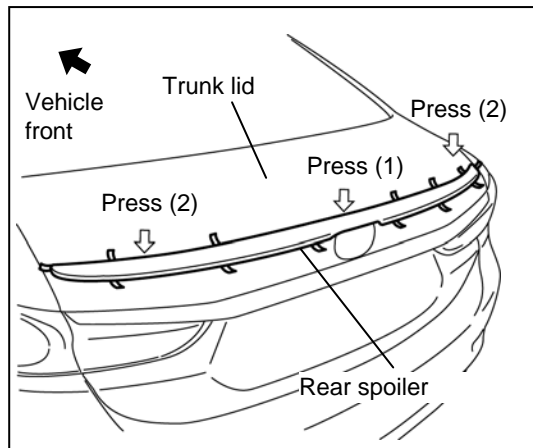

7. Remove the double-sided adhesive tape backings from the rear spoiler in the direction of the arrows in the order of 1 to 3, and affix securely.

- Perform the procedure while lifting up the rear spoiler from the trunk lid slightly so as not to tear the tape backing.
- Do not remove the rear spoiler once it has been affixed to the accessory to prevent loss of adhesive strength.

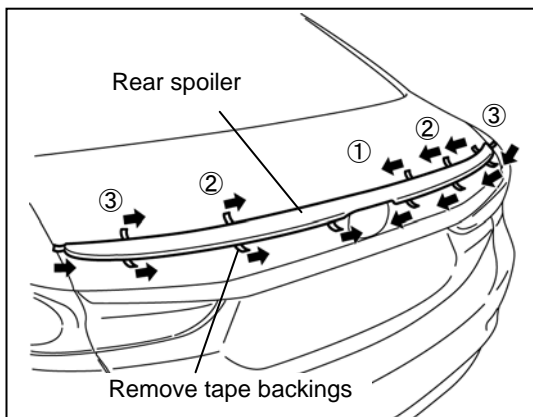

8. Fully tighten the rear spoiler using the nuts (4).

**Nut tightening torque:
3.9-6.8 Nm (40-69 kgf/cm, 35-60 in/lbf)**

- Tighten the nuts securely. Make sure to tighten to the specified torque. If tightened outside the specified torque, the rear spoiler could be damaged or fall off.

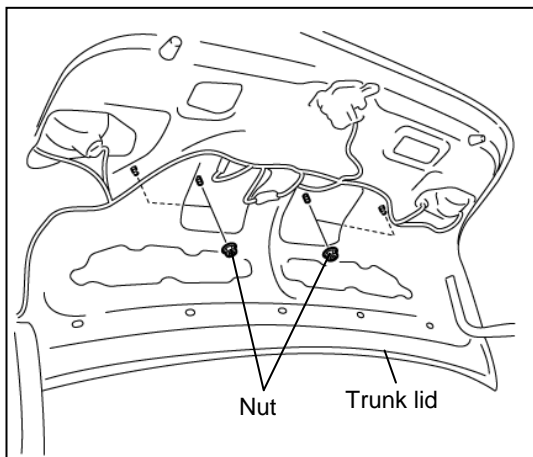

9. After installing the rear spoiler, install the trunk lid trim in the reverse order of removal.

6. To the customer

Heed the following cautions when handling (maintenance) the rear spoiler.

- If gasoline, oil, engine coolant, or battery fluid adheres to the hard plastic parts, it will cause discoloration, stains, or damage. Wipe off immediately with a soft cloth.
- Depending on the type of high pressure car washer used, the water for washing may be high temperature and/or under high pressure. Be careful when using pressurized water from a car washer nozzle. If the nozzle is too close or water pressure is applied for long periods, it may cause deformation or damage to the hard plastic parts.
- Do not use car wax containing compound (polishing powder). Otherwise, the hard plastic parts could be damaged.
- Do not use electric or air tools to apply wax or compound (polishing powder). Otherwise, friction heat will be generated causing deformation or damage to the hard plastic parts.

Date _____, _____, _____				
VIN _____				
Approved		Checked		Person in charge

INSTALLATION INSPECTION SHEET	MAZDA6	Rear spoiler
		0000-8Y-H50 GHK1 V4 920 G44B V4 920

Perform the following inspections

1. Inspection items after installation

Check

- Verify the fitting between the vehicle part and the installed part, and inspect for damage or dirt.

2. Vehicle parts reinstallation

Inspected part	Inspection item	Inspection	Check
Trunk trim	Rattling	Inspect the trim for looseness or drop off.	

3. Installation of accessory, operation check

Inspected part	Inspection item	Inspection	Check
Rear spoiler installation	Looseness	Inspect the installation area for looseness.	